

General purpose operational amplifier

μ A741/ μ A741C/SA741C

DESCRIPTION

The μ A741 is a high performance operational amplifier with high open-loop gain, internal compensation, high common mode range and exceptional temperature stability. The μ A741 is short-circuit-protected and allows for nulling of offset voltage.

FEATURES

- Internal frequency compensation
- Short circuit protection
- Excellent temperature stability
- High input voltage range

PIN CONFIGURATION

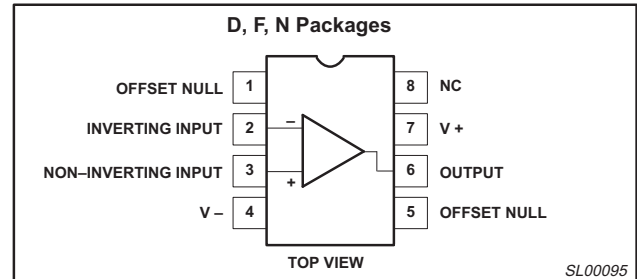

Figure 1. Pin Configuration

ORDERING INFORMATION

DESCRIPTION	TEMPERATURE RANGE	ORDER CODE	DWG #
8-Pin Plastic Dual In-Line Package (DIP)	-55°C to +125°C	μ A741N	SOT97-1
8-Pin Plastic Dual In-Line Package (DIP)	0 to +70°C	μ A741CN	SOT97-1
8-Pin Plastic Dual In-Line Package (DIP)	-40°C to +85°C	SA741CN	SOT97-1
8-Pin Ceramic Dual In-Line Package (CERDIP)	-55°C to +125°C	μ A741F	0580A
8-Pin Ceramic Dual In-Line Package (CERDIP)	0 to +70°C	μ A741CF	0580A
8-Pin Small Outline (SO) Package	0 to +70°C	μ A741CD	SOT96-1

ABSOLUTE MAXIMUM RATINGS

SYMBOL	PARAMETER	RATING	UNIT
V_S	Supply voltage		
	μ A741C	± 18	V
	μ A741	± 22	V
P_D	Internal power dissipation		
	D package	780	mW
	N package	1170	mW
	F package	800	mW
V_{IN}	Differential input voltage	± 30	V
V_{IN}	Input voltage ¹	± 15	V
I_{SC}	Output short-circuit duration	Continuous	
T_A	Operating temperature range		
	μ A741C	0 to +70	°C
	SA741C	-40 to +85	°C
	μ A741	-55 to +125	°C
T_{STG}	Storage temperature range	-65 to +150	°C
T_{SOLD}	Lead soldering temperature (10sec max)	300	°C

NOTES:

1. For supply voltages less than $\pm 15V$, the absolute maximum input voltage is equal to the supply voltage.

General purpose operational amplifier

 μ A741/ μ A741C/SA741C

DC ELECTRICAL CHARACTERISTICS

 $T_A = 25^\circ\text{C}$, $V_S = \pm 15\text{V}$, unless otherwise specified.

SYMBOL	PARAMETER	TEST CONDITIONS	μ A741			μ A741C			UNIT
			Min	Typ	Max	Min	Typ	Max	
V_{OS}	Offset voltage	$R_S=10\text{k}\Omega$ $R_S=10\text{k}\Omega$, over temp.		1.0	5.0		2.0	6.0	mV
$\Delta V_{OS}/\Delta T$				1.0	6.0		7.5		mV
I_{OS}	Offset current	Over temp. $T_A=+125^\circ\text{C}$ $T_A=-55^\circ\text{C}$		20	200		20	200	nA
$\Delta I_{OS}/\Delta T$				7.0	200		300		nA
I_{BIAS}	Input bias current	Over temp. $T_A=+125^\circ\text{C}$ $T_A=-55^\circ\text{C}$		80	500		80	500	nA
$\Delta I_B/\Delta T$				30	500		800		nA
V_{OUT}	Output voltage swing	$R_L=10\text{k}\Omega$ $R_L=2\text{k}\Omega$, over temp.	± 12	± 14		± 12	± 14		V
				± 10	± 13		± 10	± 13	
A_{VOL}	Large-signal voltage gain	$R_L=2\text{k}\Omega$, $V_O=\pm 10\text{V}$ $R_L=2\text{k}\Omega$, $V_O=\pm 10\text{V}$, over temp.	50	200		20	200		V/mV
				25			15		
	Offset voltage adjustment range			± 30			± 30		mV
PSRR	Supply voltage rejection ratio	$R_S \leq 10\text{k}\Omega$ $R_S \leq 10\text{k}\Omega$, over temp.					10	150	$\mu\text{V}/\text{V}$
					10	150			
CMRR	Common-mode rejection ratio	Over temp.				70	90		dB
				70	90				
I_{CC}	Supply current	$T_A=+125^\circ\text{C}$ $T_A=-55^\circ\text{C}$		1.4	2.8		1.4	2.8	mA
				1.5	2.5				mA
				2.0	3.3				mA
V_{IN}	Input voltage range	(μ A741, over temp.)	± 12	± 13		± 12	± 13		V
R_{IN}	Input resistance		0.3	2.0		0.3	2.0		M Ω
P_D	Power consumption	$T_A=+125^\circ\text{C}$ $T_A=-55^\circ\text{C}$		50	85		50	85	mW
				45	75				mW
				45	100				mW
R_{OUT}	Output resistance			75			75		Ω
I_{SC}	Output short-circuit current		10	25	60	10	25	60	mA

General purpose operational amplifier

 μ A741/ μ A741C/SA741C**DC ELECTRICAL CHARACTERISTICS** $T_A = 25^\circ\text{C}$, $V_S = \pm 15\text{V}$, unless otherwise specified.

SYMBOL	PARAMETER	TEST CONDITIONS	SA741C			UNIT
			Min	Typ	Max	
V_{OS}	Offset voltage	$R_S = 10\text{k}\Omega$		2.0	6.0	mV
$\Delta V_{OS}/\Delta T$		$R_S = 10\text{k}\Omega$, over temp.		10	7.5	$\mu\text{V}/^\circ\text{C}$
I_{OS}	Offset current	Over temp.		20	200	nA
$\Delta I_{OS}/\Delta T$				200	500	$\text{pA}/^\circ\text{C}$
I_{BIAS}	Input bias current	Over temp.		80	500	nA
$\Delta I_B/\Delta T$				1	1500	$\text{nA}/^\circ\text{C}$
V_{OUT}	Output voltage swing	$R_L = 10\text{k}\Omega$	± 12	± 14		V
		$R_L = 2\text{k}\Omega$, over temp.	± 10	± 13		V
A_{VOL}	Large-signal voltage gain	$R_L = 2\text{k}\Omega$, $V_O = \pm 10\text{V}$	20	200		V/mV
		$R_L = 2\text{k}\Omega$, $V_O = \pm 10\text{V}$, over temp.	15			V/mV
	Offset voltage adjustment range			± 30		mV
PSRR	Supply voltage rejection ratio	$R_S \leq 10\text{k}\Omega$		10	150	$\mu\text{V}/\text{V}$
CMRR	Common mode rejection ration		70	90		dB
V_{IN}	Input voltage range	Over temp.	± 12	± 13		V
R_{IN}	Input resistance		0.3	2.0		$\text{M}\Omega$
P_d	Power consumption			50	85	mW
R_{OUT}	Output resistance			75		Ω
I_{SC}	Output short-circuit current			25		mA

AC ELECTRICAL CHARACTERISTICS $T_A = 25^\circ\text{C}$, $V_S = \pm 15\text{V}$, unless otherwise specified.

SYMBOL	PARAMETER	TEST CONDITIONS	μ A741, μ A741C			UNIT
			Min	Typ	Max	
R_{IN}	Parallel input resistance	Open-loop, $f = 20\text{Hz}$	0.3			$\text{M}\Omega$
C_{IN}	Parallel input capacitance	Open-loop, $f = 20\text{Hz}$		1.4		pF
	Unity gain crossover frequency	Open-loop		1.0		MHz
t_R	Transient response unity gain Rise time	$V_{IN} = 20\text{mV}$, $R_L = 2\text{k}\Omega$, $C_L \leq 100\text{pF}$		0.3		μs
				5.0		%
SR	Slew rate	$C \leq 100\text{pF}$, $R_L \geq 2\text{k}\Omega$, $V_{IN} = \pm 10\text{V}$		0.5		$\text{V}/\mu\text{s}$

General purpose operational amplifier

μ A741/ μ A741C/SA741C

EQUIVALENT SCHEMATIC

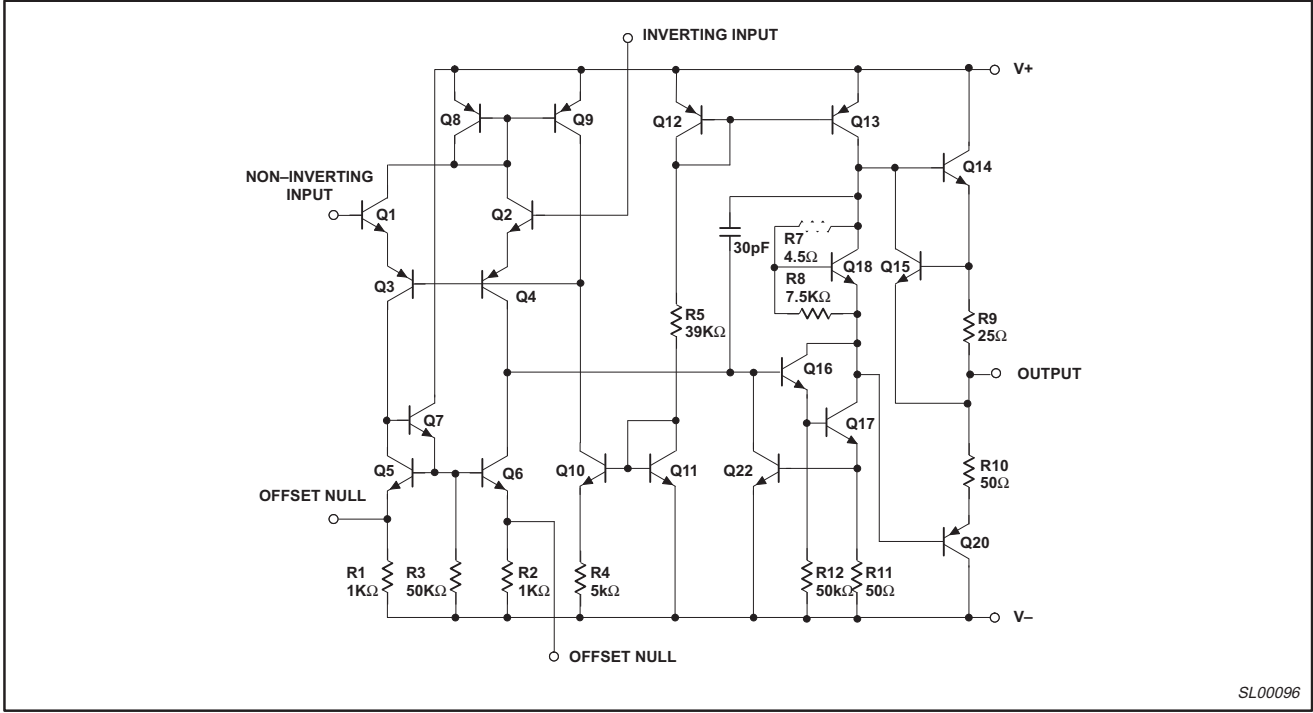

Figure 2. Equivalent Schematic

General purpose operational amplifier

μ A741/ μ A741C/SA741C

TYPICAL PERFORMANCE CHARACTERISTICS

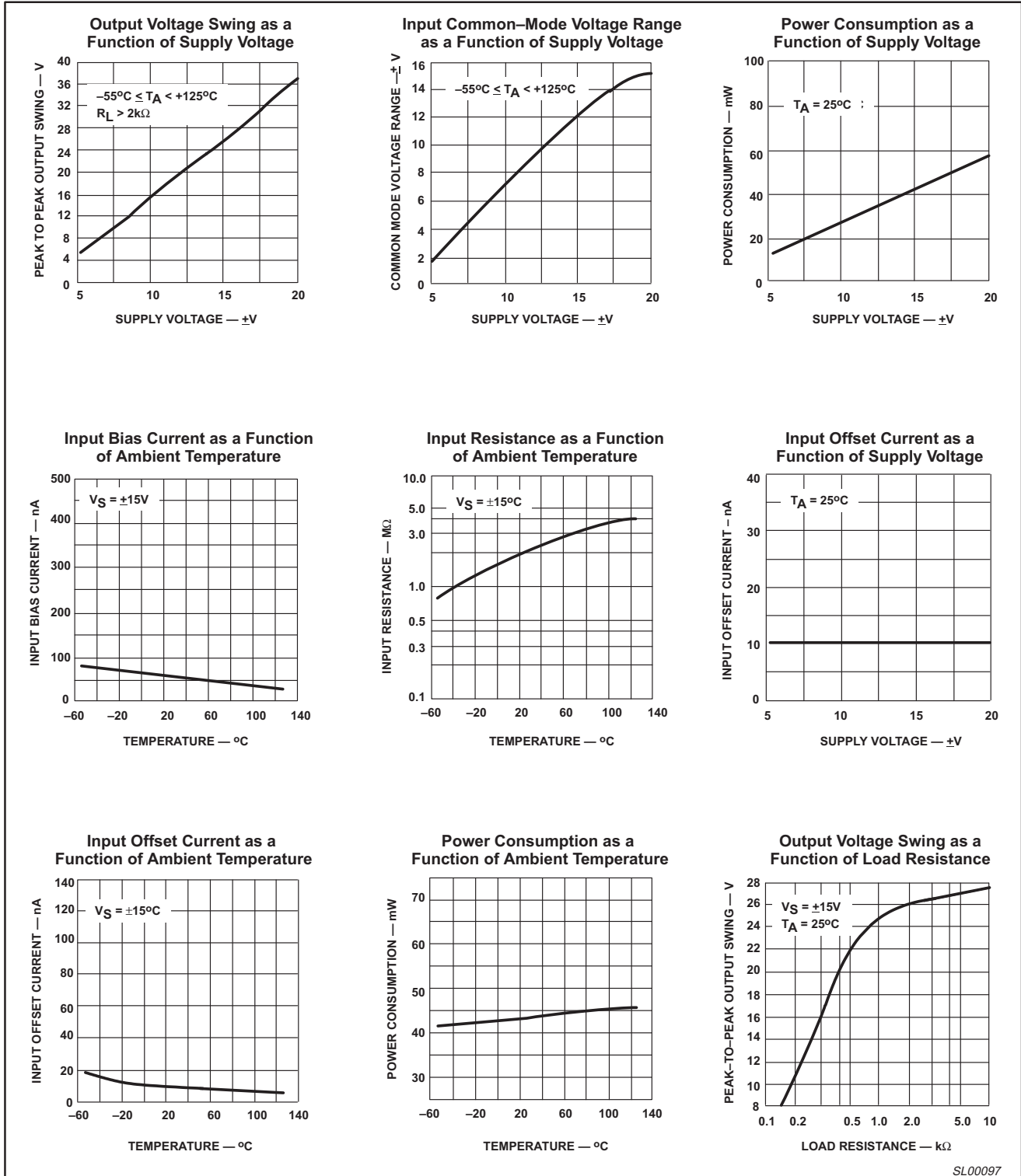

Figure 3. Typical Performance Characteristics

General purpose operational amplifier

μ A741/ μ A741C/SA741C

TYPICAL PERFORMANCE CHARACTERISTICS (Continued)

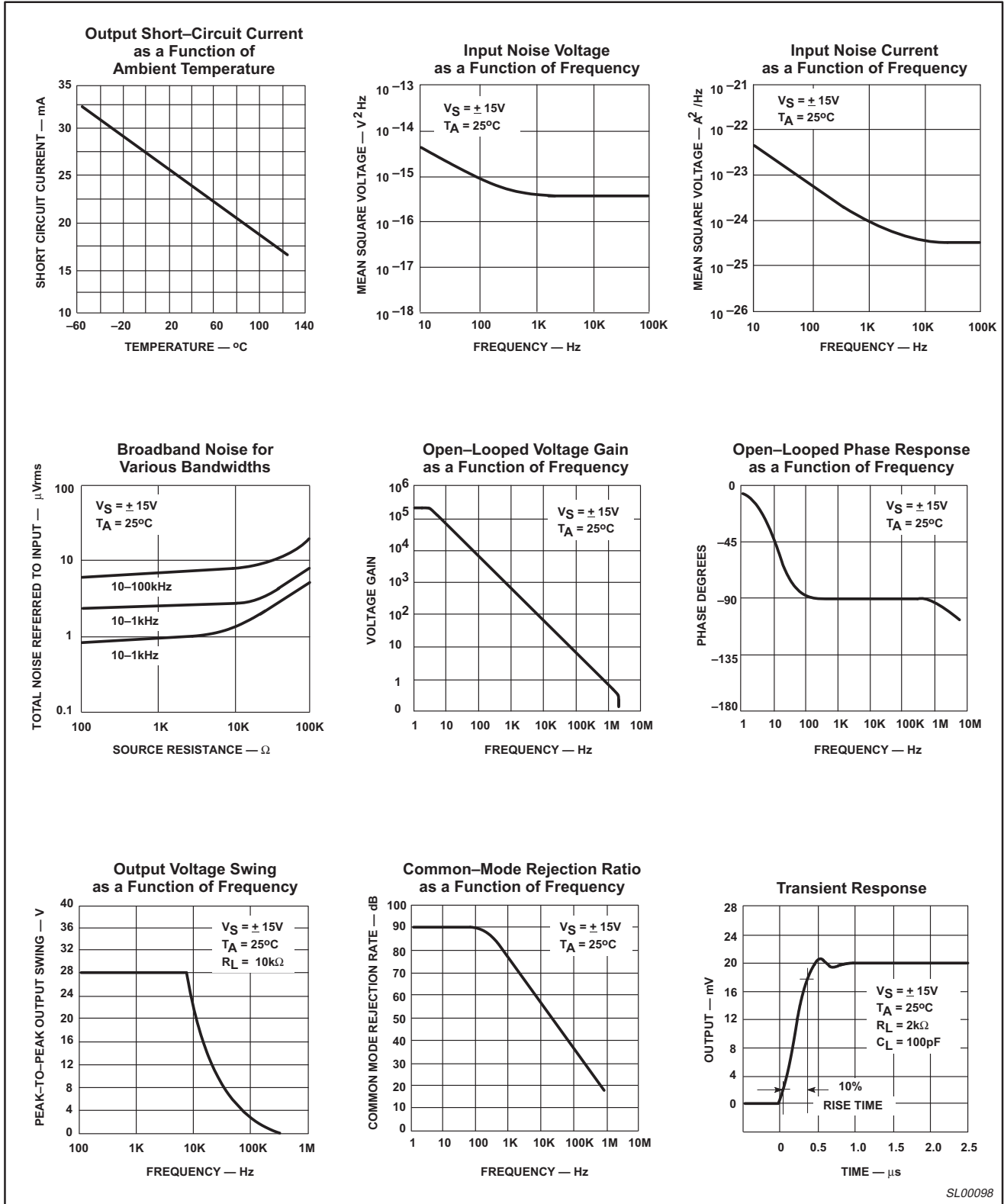

Figure 4. Typical Performance Characteristics (cont.)

General purpose operational amplifier

μ A741/ μ A741C/SA741C

TYPICAL PERFORMANCE CHARACTERISTICS (Continued)

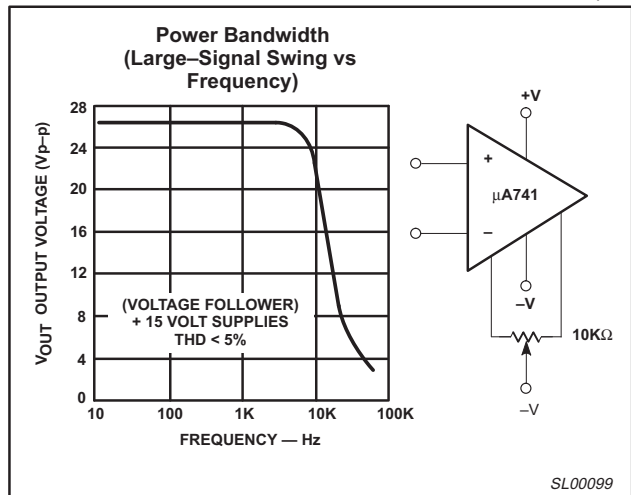

Figure 5. Typical Performance Characteristics (cont.)